



# SALTDogg<sup>®</sup>

## SPREADERS

### 7, 8, & 9 CU. YD. SALT & SAND SPREADERS

HYDRAULIC DRIVE



Chute Design provides greater material flow adjustability

Shown with Optional  
**LB8663SST**  
(Light Bar) & **LS4**  
(Liquid Spray System)

MODEL	DRIVE	GEARBOX RATIO	(LEVEL) CUBIC YARDS	(ROUNDED) CUBIC YARDS	SIDE HEIGHT	EMPTY WEIGHT
1450757SSH	Hydraulic	50:1	7	8.3	57	2,760 lbs.
1425757SSH	Hydraulic	25:1	7	8.3	57	2,760 lbs.
1450863SSH	Hydraulic	50:1	8.3	9.6	63	2,910 lbs.
1425863SSH	Hydraulic	25:1	8.3	9.6	63	2,910 lbs.
1450969SSH	Hydraulic	50:1	9.6	12.2	69	3,000 lbs.
1425969SSH	Hydraulic	25:1	9.6	12.2	69	3,000 lbs.

## IDEAL FOR HEAVY-DUTY MUNICIPAL & COMMERCIAL APPLICATIONS

Designed for municipalities and contractors with a minimum 26,000 lbs. GVW chassis.

### GENERAL:

- Self-contained hopper.
- Spreads free flowing materials sand and/or salt.
- Spread width of 4' to 40'.

### MATERIAL HOPPER:

- 7-gauge 304 stainless steel cross members.
- 10-gauge 304 stainless steel, long sills with rear enclosure & integral chain shields.
- 10-gauge 304 stainless steel replaceable floor.
- 10-gauge 304 stainless steel sides (continuously welded seams), gussets and rear panel.
- 10-gauge 304 stainless steel front panel.
- Four (4) 5/8" thick lift points.

### FEEDGATE:

- 10-gauge, 304 stainless steel with scaled screw jack adjustment.
- 18-5/8" W x 10" T opening.

### CONVEYOR:

- 24" wide, pintle chain conveyor with 3/8" thick x 1-1/2" wide crossbars on 4-1/2" centers (667X Pitch).
- 2" diameter drive shaft with 4-bolt relubeable bearing.
- 8-tooth cast iron sprockets.
- 50:1 or 25:1 direct-drive gearbox with extended through-shaft for ground speed sensor.
- 1-1/2" diameter idler shaft with 4" adjustable range relubeable bearing.
- Conveyor chain wiper made of belted rubber minimizes waste.

### STANDARD INSTALLED EQUIPMENT:

- 4-section hinged top grate screens. 3/8" diameter bar on 3" centers with 1/4" x 2" x 2" angle iron frame. Hinged to 6" horizontal cross beam.
- 10-gauge, 304 stainless steel inverted "V" prevents material compaction and reduces wear on drive train components.

### CHUTE/SPINNER ASSEMBLY:

- 10-gauge, 304 stainless steel laser cut parts with smooth radius corners.
- Telescopic adjustment in 3" increments to accommodate varying body mounting heights.
- Two (2) adjustable, internal baffles direct material to 20" diameter x 5/8" thick, 6 fin poly spinner disc.

- Three (3) adjustable external and one (1) fixed deflector with overlapping corners provide a precision spread pattern.
- Top-mounted, direct-drive hydraulic spinner motor provides better ground clearance and corrosion protection.
- Two (2) stainless steel spring latches quick release hinged chute for bulk material unloading and convenient ground storage.

### POWER SOURCE:

- Hydraulic Drive: Two independent direct drive hydraulic motors (17 GPM @ 1,500 PSI).

### OPTIONAL EQUIPMENT:

- Dump Body Tailgate Latch Kit (Part # 3008560).
- DOT Spreader Lightbar (Part # LB8663SST). 8" Tall x 66" Long x 3" Deep stainless steel lightbar includes 9 mounting holes for 4" recessed stop-turn-taillights-strobes and 2-1/2" marker lights.
- Liquid Spray System (Part # LS4). Shown below. 104 Gallons.
- Tie-Down Kit (Part # 3010548).

### DIMENSIONS:

- Hopper length, 120"; Overall length, 143"; Width, 82"; Recommended use, dump bodies and flat beds with a minimum 26,000 lbs. GVW chassis.

### LS4

- Provides more efficient salt distribution
- Speeds the melting process
- Works at lower temperatures than salt
- Residual material on the pavement lasts longer
- Reduces the number of applications required

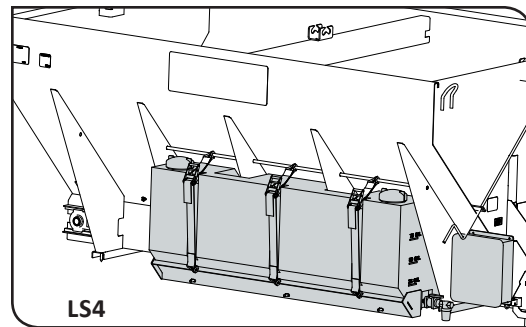

Buyers Products Company reserves the right to change material, dimension and/or component specifications without notice.

### CONTACT:



Providing lifting solutions  
for every need

[pmindustries.ca](http://pmindustries.ca)

Toll Free: 1-855-656-1689



Your Authorized SaltDogg® Distributor