

KM 401H

Pallet Fork

hydraulically shifting & tines with spindle adjustment

The efficient pallet fork KM 401H with a hydraulically compensating centre of gravity can easily be adapted to different loads with adjustable plunge depth and adjustable tine spread.

- **Efficient handling** of many different kinds of loads in an economic, one-man operation is possible due to the hydraulic shifting of the KM 401H. It saves you time and money.
- **Precise positioning** of the loads is no problem in combination with the **KINSHOFER** rotator – continuous rotation, precise start and braking ability.
- **Versatile height** from 1000 mm to 1600 mm adjustable in three steps with a lock pin.
- **Versatile width** of tines from approx. 475 mm to 815 mm adjustable with a smooth running, stainless spindle.
- **Easy to use** due to the dimensions of the KM 401H. Since no part of the KM 401H pallet fork is wider than a standard pallet, a second row can be loaded. As no part of the pallet fork is wider than the tines, loads close to walls can be handled without problems.



Package Pallet Fork KM 401H-1500 c

Type	Load capacity (kg)	Throat height A (mm)	Tine length (mm)	Tine spread Z (mm)	Tine dimensions (width x height) (mm)	Centre of gravity (mm)	Self weight (kg)
KM 401H-1500 c	1500	1000 – 1600	980	475 – 815	80 x 35	500	155

Package consists of: pallet fork, rotator KM 04 F, short connecting hoses KM 203 01 (rotator to fork), upper suspension KM 501 4500, protection chain KM 460 01

Pallet Fork KM 401H

Type	Load capacity (kg)	Throat height A (mm)	Tine length (mm)	Tine spread Z (mm)	Tine dimensions (width x height) (mm)	Centre of gravity (mm)	Self weight (w/o rotator) (kg)
KM 401H-1500-500	1500	1000-1600	980	475 – 815	80 x 35	500	120
KM 401H-2000-500	2000	1000-1600	980	495 – 835	100 x 35	500	135
KM 401H-2500-500	2500	1000-1600	980	490 – 830	100 x 50	500	160
KM 401H-1500-600	1500	1000-1600	1150	495 – 835	100 x 35	600	155
KM 401H-2000-600	2000	1000-1600	1150	500 – 840	100 x 50	600	170
KM 401H-2500-600	2500	1000-1600	1150	510 – 850	120 x 50	600	235

Package consists of: pallet fork, protection chain KM 460 01

Please note: a protection trellis or net is mandatory for loose material (EN 13255)

Accessories

Type	Description
KM 04 F	recommended KINSHOFER rotator for KM 401H
KM 04 S	KINSHOFER shaft rotator – up to 4500 kg load capacity
KM 505	quick change system for shaft-type rotators
KM 502 4500	reduction link between rotator and grapple
KM 460 04 KM 04 S	non-rotating hook for rotator KM 04 S

Requirements of Truck Crane

Operating pressure: max. 20 MPa (200 bar)
Pump capacity: 20 to 40 l/min

Technical Drawings

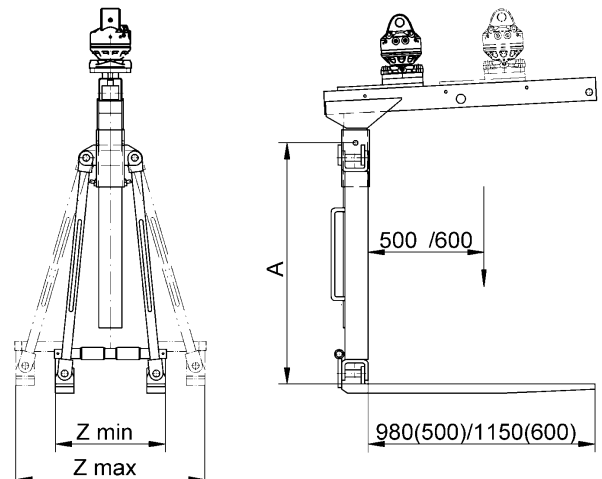

Providing lifting solutions
for every need
pmindustries.ca
 Toll Free: 1-855-656-1689